



Equinox® Advantage

**NITROUS OXIDE/ OXYGEN
ADMINISTRATION SYSTEM**
01EQ2000

TABLE OF CONTENTS

1. Introduction	4
1.1. Indications for Use	4
1.2. Contraindications	4
1.3. Product Description/Principles of Operation	4
1.4. Warranty Information	5
1.5. Safety Precautions	6
1.6. Performance Specifications	7
2. Preparation for Use	8
2.1. Component List	8
2.2. Pre-Use Functional Checks	8
3. Operating Instructions	10
3.1. Connection of Hoses	10
3.2. On/Off Selector	12
3.3. Gas Mixture Selection	12
3.4. Demand Valve	13
3.5. 100% Oxygen Enrichment Supply	13
3.6. Low Input Pressure Alarms	13
3.7. Low Input Pressure Shut Off	14
4. Preventive Maintenance And Servicing	14
4.1. Routine Maintenance	14
4.2. Cleaning	16
5. Schematic Flow Diagram	17
6. Replacement Parts & Accessories	18

1. Introduction

1.1. Indications for Use

The Equinox® Advantage N₂O/O₂ Analgesic Gas Mixing and Delivery System is intended to administer an adjustable mixture of Nitrous Oxide analgesic gas and Oxygen, on demand, to a conscious, spontaneously breathing patient.

The device is suitable for use in:

- Pre-hospital (emergency medical) use, and
- In-hospital use (ER, Labor and Delivery etc.)

1.2. Contraindications

The contraindications for this device include, but may not be limited to:

- Hypersensitivity to the medication
- Head injuries with impaired consciousness
- Maxillofacial injuries
- Artificial, traumatic or spontaneous pneumothorax
- Air embolism
- Middle ear occlusion, ear infection
- Decompression sickness
- Abdominal distension / intestinal obstruction

Note: Nitrous Oxide/Oxygen (N₂O/O₂) mixtures must never be used in any condition where air is trapped in the body and expansion (up to 3x original size) would be dangerous. For example, it will exacerbate pneumothorax and increase pressure from any intracranial air. Air in any other cavities such as the sinuses, middle ear and abdomen may also expand.

1.3. Product Description/Principles of Operation

Two input connectors are provided on the device for the connection of pressure regulated gas sources of nitrous oxide and oxygen. The device has only one control for turning ON or OFF. When it is turned ON, the output of N₂O/O₂ gas mixture will only be activated by an inspiratory effort by the patient. The output of gas mixture can be selected among various percentages from 25%/75% (O₂/N₂O) to 100%/0% (O₂/N₂O).

The gas specific built-in alarm systems will generate both visual and audible alarms should either the nitrous oxide or oxygen input fall below 40 PSI, and the device will be automatically shut

off should the oxygen input fall below 35 PSI. Both visual indicator and audible alarm circuits for both gasses are powered by oxygen only to prevent dumping nitrous oxide gas into atmosphere during alarm cycling.

If Oxygen Supply runs out or shuts off, the device will automatically shut off; however the device will continue to provide atmospheric room air on demand to the patient.

An Oxygen Enrichment function allows the healthcare professional to provide a constant flow of 100% oxygen to the patient.

Note: The O-Two Equinox® Advantage System is considered a critical device, and its components considered critical components. Only those individuals trained in the operation of nitrous oxide/oxygen analgesic gas delivery systems should use this equipment. Thoroughly review the instruction manual before use.

1.4. Warranty

WARRANTY

O-Two Medical Technologies Inc. products are manufactured from the finest quality materials. Each individual part is subject to strict quality control tests to ensure exceptionally high standards. The manufacturer warrants to the purchaser of the O-Two Equinox® Advantage N₂O/O₂ Analgesic Gas Mixing and Delivery System that its component parts are free from defects in material and workmanship for a period of two years from the date of purchase. The manufacturer will replace and /or repair all parts of the device at its option for two years from the date of purchase at no cost to the purchaser, upon the notification of the defects, in writing by the purchaser. All shipping costs shall be borne by the purchaser. The manufacturer shall be liable under this warranty only if the device and its parts have been used and serviced in the normal manner described in the instruction manual. There are no other expressed or implied warranties. This warranty gives no specific legal rights. You may also have other rights which may vary according to local regulations.

1.5. Safety Precautions

The O-Two Equinox® Advantage is a self-administered device intended to administer an adjustable mixture of nitrous oxide analgesic gas and oxygen, self-administered on demand, to a conscious, spontaneously breathing patient.

The following precautions should always be observed:

WARNING

1. Do not smoke or use near open flame either during operation or when changing the cylinder.
2. Never allow oil or grease to come into contact with any part of the cylinder, regulator or Equinox® Advantage System. Gas mixer has been degreased for oxygen service prior to delivery.
3. Equinox® Advantage System is designed for patient self-administration.
4. Never attach the facemask to the patient using a head harness.
5. If the alarm sounds continuously, immediately discontinue use and shut off the gas supply.
6. It is recommended that an oxygen monitor be used with this device to monitor the gas output. However, if there is a concern that the device has not undergone regular maintenance, at the prescribed intervals, in accordance with this manual, then an oxygen monitor shall be used.
7. It is recommended to use cylinders that are at least 1/4 full.
8. Medical gases must be dry and free from dust and oil.

CAUTION:

9. The nitrous oxide cylinder should be operated in an upright position. If the nitrous oxide cylinder is in a valve-down position while the post valve is open, liquid may be expelled through the vent passages. This liquid, nitrous oxide, can cause burns by freezing on exposed skin.
10. Always turn on cylinder valve slowly and fully.
11. When not in use, always turn off the cylinder.
12. After use, always ensure that a gas cylinder with sufficient volume is attached before returning the unit to its normal storage position.
13. After use, always ensure that all components are cleaned in accordance with the instructions provided in this manual.

14. Do not disassemble any part of the unit except where described in this manual as any unauthorized disassembly will invalidate the warranty.
15. Before use on a patient, the oxygen concentration of the delivered gas should be checked at the setting intended for use.
16. Us federal law restricts this device to sale by or on the order of a physician.

1.6. Performance Specifications

Minimum Flow rate	120 L/min
Exhalation Resistance	0 to 6 cmH ₂ O @ 60 L/min
Inhalation Resistance	0 to -6 cmH ₂ O @ 60 L/min
Oxygen Concentrations (±5%V/V at Minimum Demand Flow 20 L/min)	25, 40, 50, 60, 70, 75, 90, 100%
Input Pressure	50 to 70 PSI (3.5 - 4.8 Bar)
Low Input Pressure Alarm	40 ± 1 PSI (2.7 Bar)
Device Cut-off Pressure	35 ± 2 PSI (2.4 Bar)
Demand Valve Triggering Pressure	-1.5 to -2.5 cmH ₂ O
Oxygen Enrichment Flow	30 ± 5 L/min
Operating Temperature	41°F to 104°F (5°C to 40°C)
Storage Temperature	-40°F to 140°F (-40°C to 60°C)
Device Input Connections	Nitrous Oxide: CGA1040 DISS Oxygen: CGA1240 DISS
Supply Hose Connections	Refer to Section 6
Patient Connector	15/22 mm
Patient Circuit (Single use)	Dual limb circuit with one-way valves and 19 mm Scavenging Port Connection on the exhalation limb
Patient Valve Dead Space	32 ml
Weight	4.4 lb. (2.0 Kg)
Dimensions W x D x H	9.27"x7.6"x4.4" (236x194x112mm)

2. Preparation for Use

2.1. Component List

Ensure that all the following components have been received:

1. Operating Manual
2. O-Two Equinox® Advantage System
3. Single Use Patient Circuit with Mouth Piece
4. Oxygen Supply Hose
5. Nitrous Oxide Supply Hose

If any components are missing from the shipping carton, call the supplier immediately.

2.2. Pre-Use Functional Checks

Along with the contents of the shipping cartons you will require the following items to enable you to undertake the pre-use functional check:

- Nitrous oxide and oxygen pressure sources with 60 PSI output capable to provide a minimum of 100 L/min at no less than 42 PSI (2.9 Bar).
- Vacuum generator w/30 L/min flowrate

Leak test

Having connected the supply hoses (ISO 5359 compliant) to the regulators (refer section 3.1 for CONNECTION OF HOSES), ensure that the O-Two Equinox® Advantage System ON/OFF selector is in the OFF position and turn on the N₂O and O₂ Gas source. Using a mild soap solution, spray the input connections to the device to check for leaks. If any leak is present, tighten the connection and re-test. Once no leakage is confirmed, turn the ON/OFF control to the ON position.

Reverse gas flow test

Equinox® Advantage is designed to meet “reverse flow” requirement of ISO 11195. It is recommended to test the reverse flow as follows before use:

Connect one gas at a time to the corresponding input connector, spray the other input connector, no bubbles allowed from this connector.

Function test

The following features of Equinox® Advantage System can be individually tested or measured using calibrated pressure gauge and flowmeter during the pre-use Functional Check:

1. Demand Valve Function

Apply a vacuum to the patient connector equivalent to a flow rate of 30 L/min for a minimum of 1 second. The demand valve will provide a flow rate equivalent to that demanded. Remove the vacuum from the patient connector; the flow from patient connector should stop.

Note:

1. Ensure performing this test using the single use patient circuit for this device otherwise the demand valve will free flow.
2. The vacuum source can be as simple as a 1 Liter gas calibration syringe.

2. Low Input Pressure Alarms

Note: To fully test this function it is necessary to have a supply regulator with an adjustable output pressure and a release valve (Not supplied). Checking of the alarm can be undertaken by simply slowly closing the cylinder valve.

With the adjustable outlet pressure regulator set with an outlet pressure of 50 PSI, gradually reduce the outlet pressure of the regulator to around 40 PSI while slowly releasing the gas until you hear the Low Input Pressure Alarm activate. For the nitrous oxide alarm the pulsed tone frequency is set at a low frequency of approximately 60 BPM. For the low oxygen alarm, the pulsed tone frequency is set at high frequency of approximately 120 BPM.

When low pressure alarm is activated, the Gas Supply Status Indicator should cycle at the same rate of the alarm.

3. Low Input Pressure Shut Off

Continue decrease oxygen regulator outlet pressure to around 35 PSI, the device should be automatically shut off.

4. Oxygen Enrichment Button

When pressed with the ON/OFF switch set to ON, Oxygen should flow out of the patient circuit.

5. Oxygen Concentration

The percentage of the oxygen concentration of the delivered gas can be determined by the following procedure:

- A.** Connect an oxygen monitor to the output connector of the Advantage using a T-Connector (as shown in Fig 2).
- B.** Utilizing a 1 Liter gas calibration syringe, connect the syringe to the patient connection on the patient circuit connected to T-connector (as shown in Fig 2). Turn on the Advantage unit, select the 100% O₂ setting and activate the demand valve by cycling the syringe until the oxygen reading on the monitor has stabilized
- C.** Repeat step “b’ for the remaining settings and confirm that the oxygen concentration reading falls within the following ranges for each setting:

Setting	Acceptable Range
25%	21 - 35
40%	30 - 50
50%	40 - 60
60%	50 - 70
70%	60 - 80
75%	65 - 85
90%	80 - 100
100%	90 - 100

Note: Factory calibration of this device uses a +/- 5% V/V tolerance. These Pre-Use tests are designed for the user to confirm function and accuracy of the device while taking into account differences in test equipment and test procedures that may affect the results obtained. Any devices with results outside of the tolerance stated in the chart should be returned to an authorized service center for checking.

3. Operating Instructions

3.1. Connection of hoses

The Equinox® Advantage System is designed to operate on medical nitrous oxide and oxygen from either pressure regulated medical gas cylinders or “piped-in” systems. The inlet fittings on the device are non-interchangeable fittings specifically for nitrous oxide and oxygen.

The device is designed to operate under 50 – 70 PSI (3.5 - 4.8 Bar) input pressures for both N₂O and O₂ gas supplies.

In case of failure in gas input systems, Equinox® Advantage is equipped with internal pressure regulators that can handle input pressure up to 1.5 times the design input pressure without having damage to internal components.

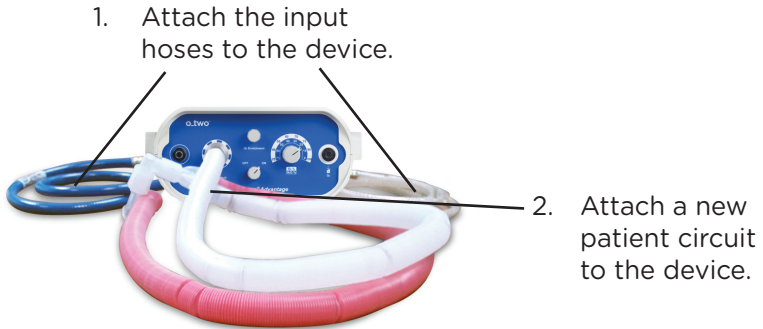

Fig.1 Connecting the Supply hoses and Patient Circuit

The nitrous oxide supply hose provided shall be attached to the N₂O input connection on the left side of the device when facing it. The oxygen supply hose provided shall be attached to the O₂ input connection on the right side of the device. Tighten the supply hoses “**Finger tight**” only – **DO NOT USE A WRENCH** (fig 1).

Note: Using a wrench or excessive force when tightening the supply hose may damage the seal of the thread of the connection.

The patient circuit is attached to the gas outlet on the front panel of the control module by simply pushing the 22 mm taper over the outlet.

3.2. ON/OFF Selector

ON/OFF SELECTOR controls the device in either normal operating function or shut off.

3.3. Gas Mixture Selection

The gas mixture selection knob allows the user to choose among 8 combinations of Oxygen and Nitrous Oxide mixtures as follows:

Setting	1	2	3	4	5	6	7	8
O ₂ %	25	40	50	60	70	75	90	100
N ₂ O %	75	60	50	40	30	25	10	0

To monitor the output of the N₂O/O₂ mixture, an oxygen monitor with alarm should be used on the inspiratory line of the patient circuit. The monitor “Tee” piece is to be placed on the outlet of the mixer prior to the circuit being attached (fig 2).

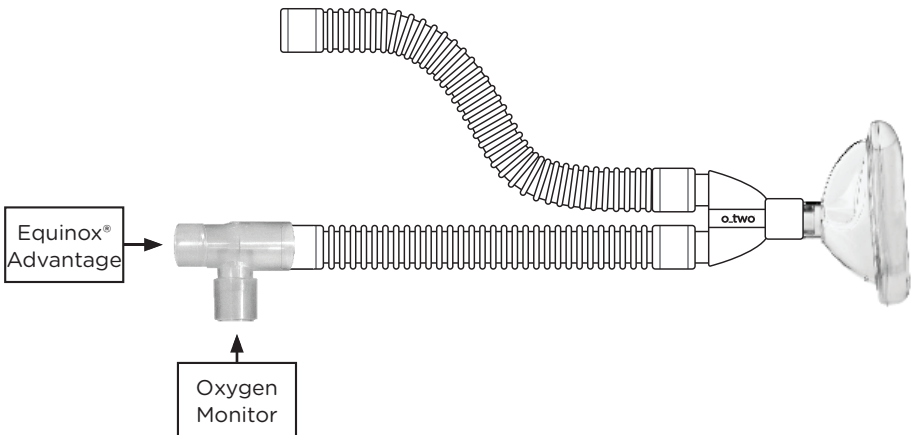

Fig. 2 - Connecting the Oxygen Monitor

Note: Placing an oxygen monitor in the above location will remove the additional monitoring line from becoming an issue for the patient if the “tee” piece is placed proximal to the facemask. Additionally, the one-way valve system in the O-Two Equinox® circuit will prevent expired air from reaching the monitor.

3.4. Demand Valve

The device is equipped with a Demand System enabling spontaneously breathing patients to demand preselected mixture percentage of nitrous oxide and oxygen.

An inspiratory effort by the patient will open the demand valve and preselected percentage mixture of nitrous oxide and oxygen will flow to the patient at a rate in line with their inspiratory effort.

3.5. 100% Oxygen Enrichment Supply

If at any time 100% Oxygen Enrichment is desired, press the Oxygen Enrichment button to activate “100% Oxygen” supply.

The Oxygen Enrichment function is designed to provide 30 L/min of 100% oxygen in order to flush any residual gas from the patient circuit following the completion of the patient treatment.

When the device ON/OFF switch is set to the “OFF” position or the device not connected to an oxygen supply, the Oxygen Enrichment function is disabled.

WARNING

The Oxygen Enrichment function should never be used to provide positive pressure ventilation to non-breathing patients.

3.6. Low Input Pressure Alarms

Gas Supply Status Indicators

Located on the front panel, the O₂ visual indicator shows green when oxygen is supplied to the unit and N₂O visual indicator shows green when nitrous oxide is supplied to the unit. Used in conjunction with the Low Input Pressure alarms, these indicators provide additional reference for the operator as to the gas supply status.

Low Input Pressure Alarms

The alarm system will generate a 45 to 75 BPM visual (flashing Green/Black) and an audible alarm should nitrous oxide input drop to 40 PSI. Should the oxygen input pressure drop to 40 PSI, a 90 to 150 BPM visual (flashing Green/Black) and audible alarm will be generated.

3.7. Low Input Pressure Shut Off

The device will automatically shut off should oxygen input pressure drop to 35 PSI. This indicates that the drive gas is now exhausted to the point where the device will no longer function correctly.

When only oxygen is applied, the device will not shut off, and an audible alarm will be activated with cycled N₂O visual Indicator.

When only nitrous oxide is applied, the device will automatically shut off with O₂ gas supply indicator showing black and no audible alarms activated. However the Equinox® Advantage will continue to allow the patient to breathe through the device on atmospheric room air.

4. Preventive Maintenance and Servicing

4.1. Routine Maintenance

To ensure proper operation of the O-Two Equinox® Advantage, regular inspection and checking of the device and accessories for correct function should be undertaken by a responsible member of staff. It is recommended that a preventive maintenance record be maintained for each unit.

It is recommended that the routine preventive maintenance be carried out and the Equinox® Advantage mixer be returned to O-Two Medical Technologies or its authorized service center for maintenance and service every 2 years as follows:

Monthly checking

This check is to ensure that all of the accessories and device components are present, the nitrous oxide and oxygen cylinders are full and that the device is in working order.

The device should be checked for proper function and mixing percentage (oxygen concentration) at least every six months, and more frequently in high use applications. Units with test pressures outside of the ranges listed in the product specifications should not be used.

Any malfunction unit should be returned to the manufacturer or an authorized service center since this product is not designed for field disassembly or service. Unauthorized repairs will nullify the product warranty.

Level II service

The device shall be returned to the manufacturer or a service center authorized by the manufacturer for bi-annual Level II service every 2 years.

Manufacturer full service

The device shall be returned to O-Two Medical Technologies for Manufacturer Full Service every 6 years.

	Description	Procedure	Criteria	Schedule	By
PM	Visual inspection	User Manual Chapter 4.1 Monthly checking	Device in work order, gas tanks are full, no missing item	Monthly	User
PM	Leak test	User Manual Chapter 2.2	No leak observed	Every 6 months	User
PM	Function check	User Manual Chapter 2.2 [1] - [5]	Within specification	Every 6 months	User
Servicing	Level II service	Service manual	Meet product specifications	Every 2 years	Manufacturer/ service center
Servicing	Full service	Service manual	Meet product specifications	Every 6 years	Manufacturer

4.2. Cleaning

Routine cleaning of the device shall be undertaken to maintain the device in a clean condition.

Patient circuit with mouth piece of the device is intended for single use and shall be discarded after each patient use in accordance with local protocols and replaced with a new circuit.

All other components should be wiped clean with a mild soap solution or hard surface disinfectant suitable for the materials of manufacture of the device. Under no circumstances should the complete unit be allowed to be soaked or immersed in cleaning solutions.

Detailed cleaning procedures are as follows:

1. Ensure that the device is disconnected from the gas supply source.
2. Remove N₂O and O₂ input hoses and wipe clean with a mild soap or hard surface disinfectant. Ensure no cleaning solution enters the hoses.
3. Remove the single patient use circuit from the device and dispose of safely in accordance with local protocols.
4. The enclosure of the device can be wiped over with a soft cloth and mild soap solution or hard surface disinfectant. Ensure no cleaning solution enters the input fittings. If there is ingrained contamination a soft bristled brush may be used.
5. Dry all components thoroughly.
6. Attach a new patient circuit and connect the unit to gas supply to check function prior to packaging for emergency use.

WARNING

Do not attempt to clean and sterilize any components that are designated as disposable.

5. Schematic Flow Diagram

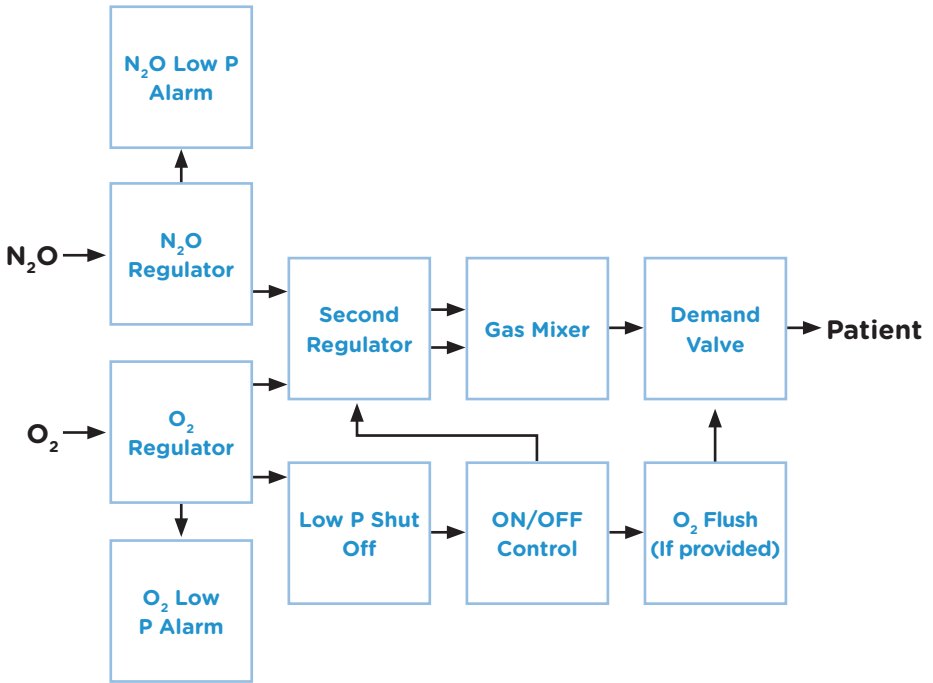

6. Replacement Parts & Accessories

ORDER N°	PART
01CV8028-Cs	O-Two Single-Use Analgesic Gas Patient Circuit with Scavenger Hose and Adapter with Mouthpiece (Case/10)
17MP1997	90° (Male to Female) adjustable Oxygen DISS elbow
17MP1998	90° (Male to Female) adjustable Nitrous Oxide DISS elbow
01FM4999	Universal Facemask (Case/12)

Oxygen Hoses*

ORDER N°	PART
01FV4303-AFNR	O-Two 6 Foot (1.85 Meter) O ₂ Supply Hose with AFNR probe and 9/16" DISS Nut Device Connection
01FV4303-AGA	O-Two 6 Foot (1.85 Meter) O ₂ Supply Hose with AGA probe and 9/16" DISS Nut Device Connection
01FV4303-CZCH	O-Two 6 Foot (1.85 Meter) O ₂ Supply Hose with CZECH probe and 9/16" DISS Nut Device Connection
01FV4303-DIN	O-Two 6 Foot (1.85 Meter) O ₂ Supply Hose with DIN probe and 9/16" DISS Nut Device Connection
01FV4303-DISS	O-Two 6 Foot (1.85 Meter) O ₂ Supply Hose with 9/16 DISS Nut and 9/16" DISS Nut Device Connection
01FV4303-UNFR	O-Two 6 Foot (1.85 Meter) O ₂ Supply Hose with UNIFOR probe and 9/16" DISS Nut Device Connection
01FV4303-BM	O-Two 6 Foot (1.85 Meter) O ₂ Supply Hose with BRITISH probe and 9/16" DISS Nut Ventilator Connection

Nitrous Oxide hoses*

ORDER N°	PART
01FV4303-AFN-N2O	O-Two 6 Foot (1.85 Meter) N ₂ O Supply Hose with AFNOR Gas Supply Fitting and N ₂ O DISS Nut Device Connection
01FV4303-AGA-N2O	O-Two 6 Foot (1.85 Meter) N ₂ O Supply Hose with AGA Gas Supply Fitting and DISS Nut Device Connection
01FV4303-CZCH-N2O	O-Two 6 Foot (1.85 Meter) N ₂ O Supply Hose with Czech Gas Supply Fitting and DISS Nut Ventilator Connection
01FV4303-DIN-N2O	O-Two 6 Foot (1.85 Meter) N ₂ O Supply Hose with DIN Nut and DISS Nut Device Connection
01FV4310	O-Two 6 Foot (1.85 Meter) N ₂ O Supply Hose with DISS Gas Supply Fitting and DISS Nut Device Connection
01FV4303-UNF-N2O	O-Two 6 Foot (1.85 Meter) N ₂ O Supply Hose with UNIFOR Gas Supply Fitting and DISS Nut Device Connection
01FV4303-BM-N2O	O-Two 6 Foot (1.85 Meter) N ₂ O Supply Hose with BRITISH Gas Supply Fitting and DISS Nut Device Connection

***Select the hose connection type for the country of use.**

Your Representative is:



O-TWO MEDICAL TECHNOLOGIES INC.

For your nearest Authorized O-Two Distributor
In North America call Toll Free 1-800-387-3405

CE 1639

EC	REP
----	-----

SERIAL Nº:	
------------	--

MedNet EC-REP GmbH
Borkstrasse, 10
48163 Münster, Germany

o_two controlled™
ventilation

www.otwo.com

45A Armthorpe Road, Brampton, ON, Canada, L6T 5M4
Telephone: +1 905 792-OTWO (6896) N.A. Toll Free: +1 800 387 3405
Facsimile: +1 905 799 1339 Email: resuscitation@otwo.com